

A Beginner's Guide to
Haunting with Commercial
Pneumatics

Joe Stone

joe@wickedstone.com

<http://www.wickedstone.com>

Pneumatics

Pneumatic Transmission of Energy

- **Energy is stored in a potential state in the form of compressed air.**
- **Potential energy travels through tubing to the point of work.**
- **Working (kinetic) energy results when compressed air is allowed to expand.**

Pneumatics (cont)

Adhoc Pneumatics

“Any facility which is used to store or control compressed air which is not designed nor intended to store or control compressed air.”

Pneumatics (cont)

Adhoc Pneumatics

- **Dishwasher Solenoid Valves**
- **PVC Air Rams**
- **Storm Door Closers**
- **Bicycle Pumps**
- **Sprinker Valves and Heads**
- ...

Pneumatics (cont)

Commercial Pneumatics

Pros:

- **More Flexible**
- **More Durable**
- **More Safe**

Pneumatics (cont)

Commercial Pneumatics

Cons (Fact or Fiction):

- **More Complicated?**
- **More Expensive?**
- **Harder to Find?**

Air Compressor

Oil-Free Pump

Craftsman 16734 - \$279

- **Noisy**
- **33 G Storage Tank**
- **6 HP, 110 VAC**
- **150 PSI Max**



Air Compressor (cont)

Oil-Lubricated

Husky VT6314 - \$429 *

- Quieter
- 60 G Storage Tank
- 7 HP, 220 VAC
- 135 PSI Max

* - No Pressure Regulator

<http://www.homedepot.com>



Solenoid Valve

- **Cylindrical coil of wire with a moveable core**
- **Core is drawn into coil as current flows switching the valve**

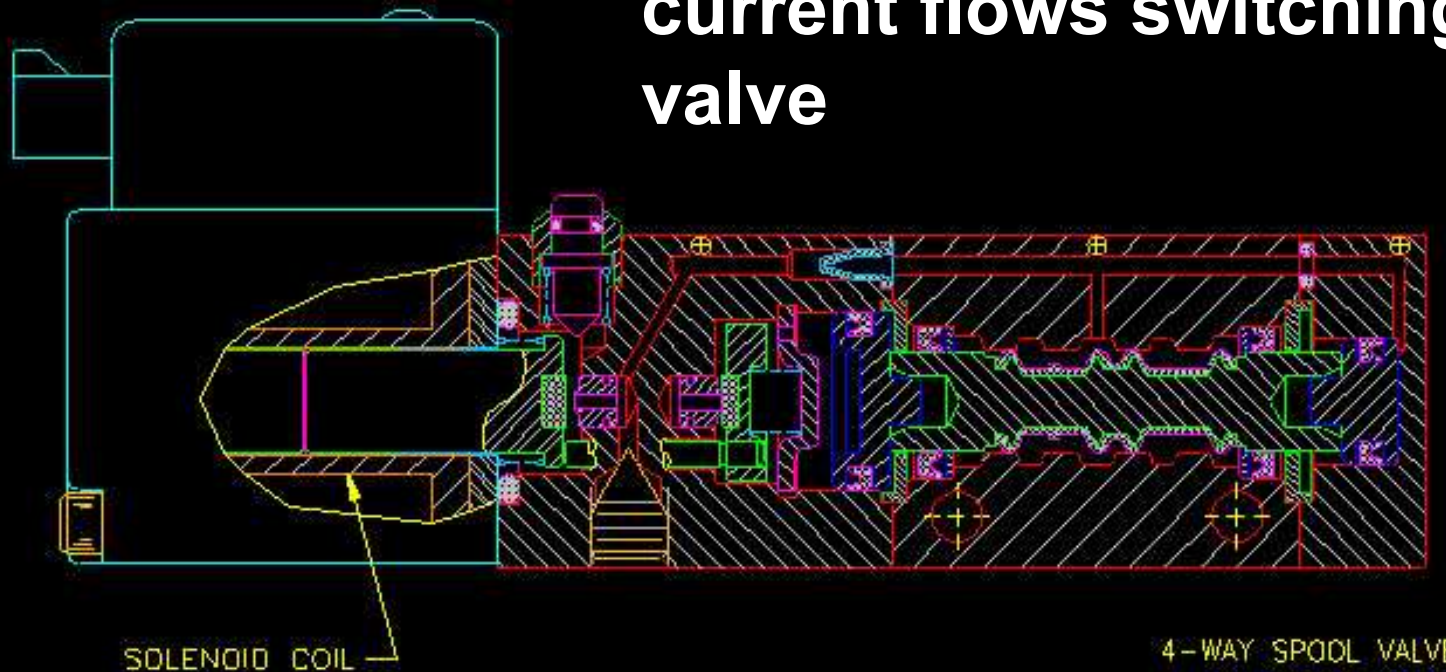

Solenoid Valve (cont)

- **Direct-Acting** - Solenoid core directly opens and closes the main orifice
- **Pilot-Operated** - Solenoid core opens a pilot orifice which relieves line pressure from a diaphragm on the main orifice



Solenoid Valve (cont)

Voltage

- 12 VDC
- 24 VDC
- 110/120 VAC

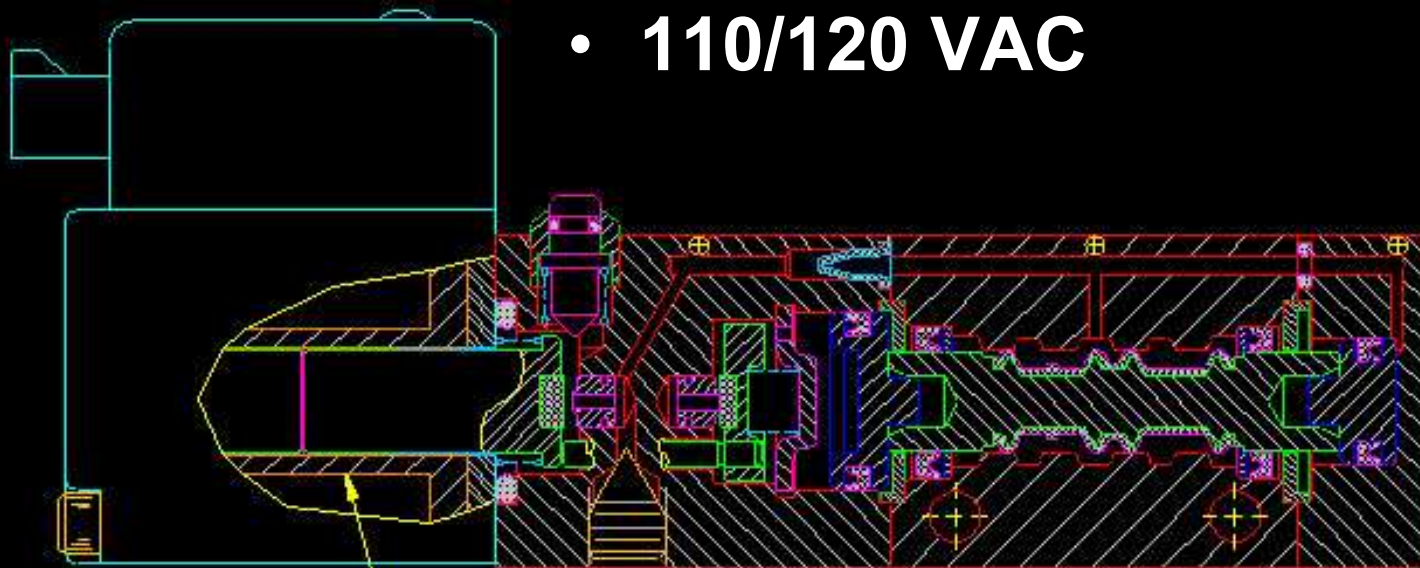



SOLENOID COIL —

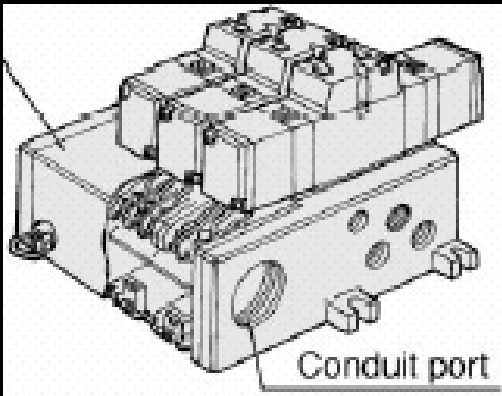

4-WAY SPOOL VALVE

Demo 1

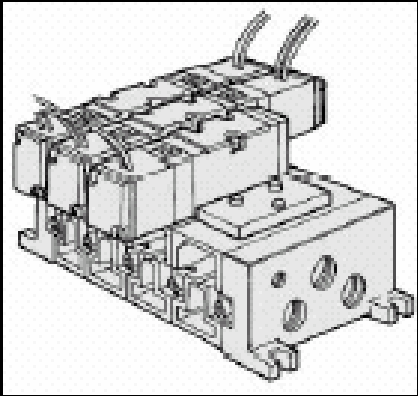
Solenoid Valve (cont)

	Sub-Plate	Manifold
Plug-In		
Non Plug-In		

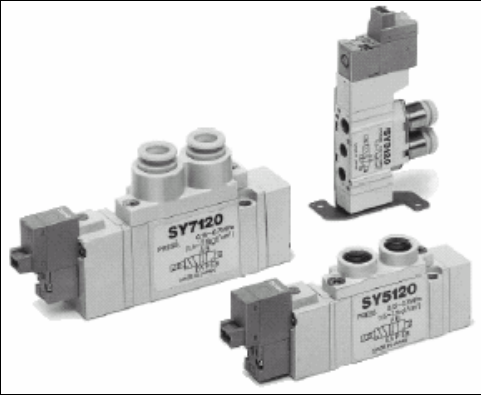
Solenoid Valve (cont)

	Single Unit	Manifold
Body-Ported, Non Plug-In		

Air Cylinder

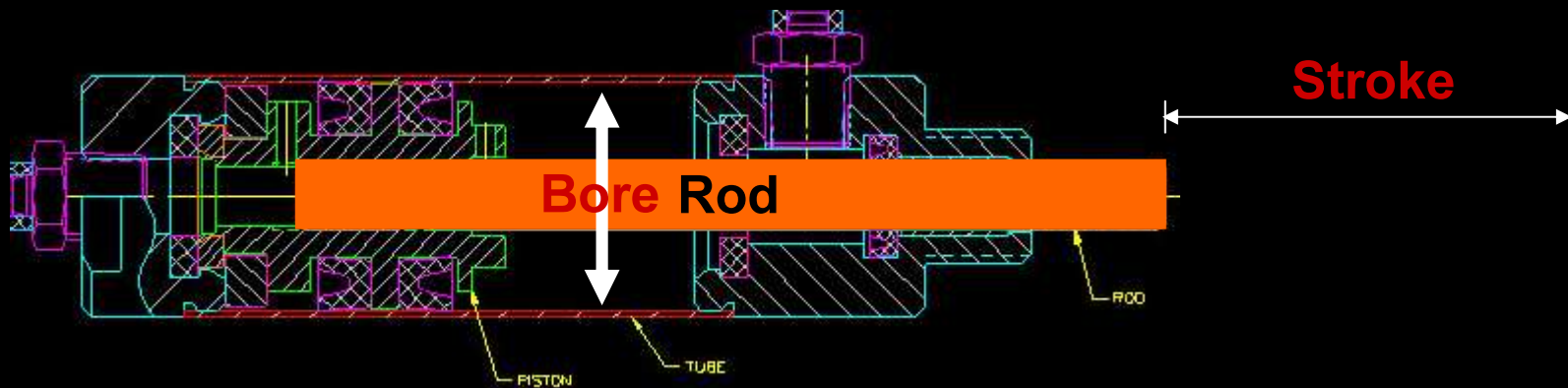

Solenoid Valve

2-Way

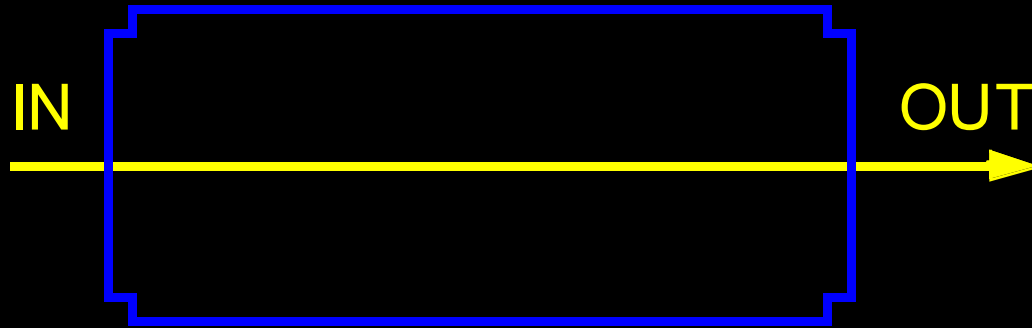

Solenoid Valve

2-Way

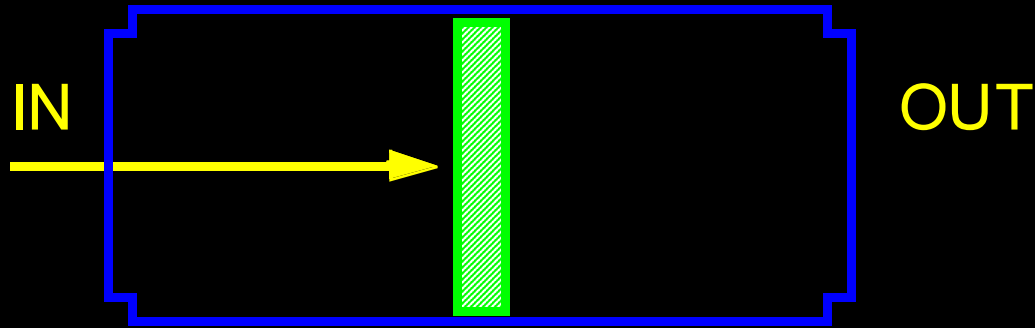

Air Cylinder

Single Acting, Stud Mount

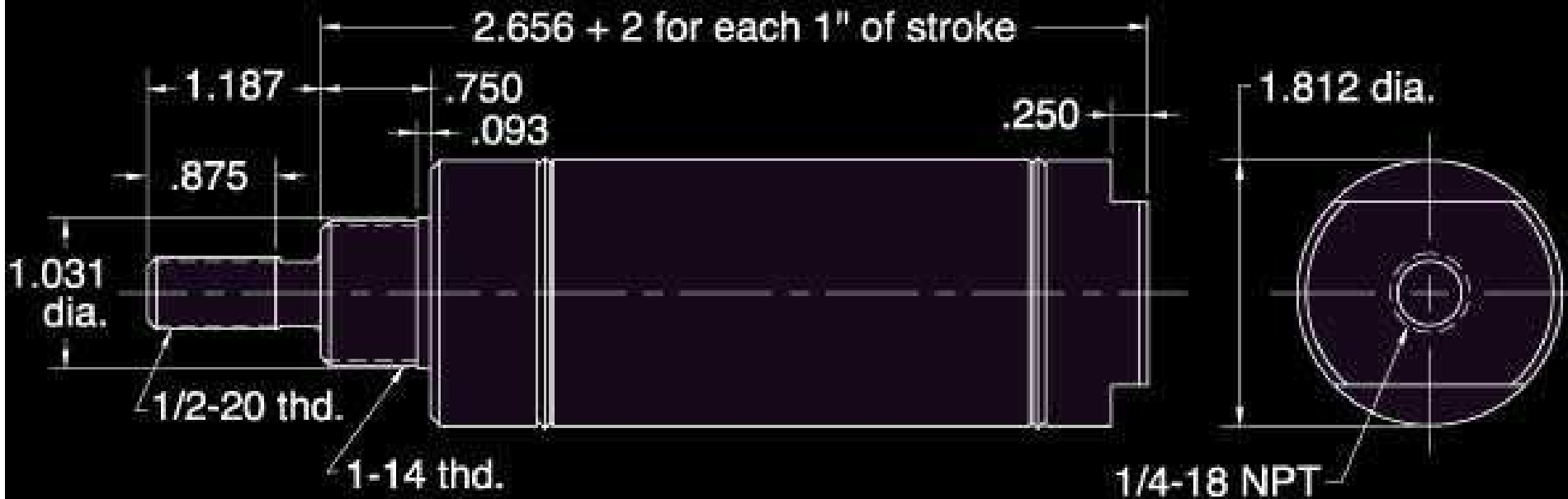

Solenoid Valve

3-Way

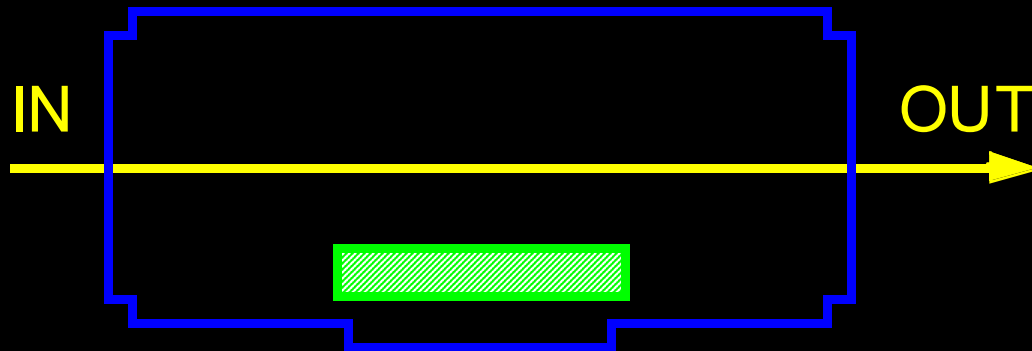

Solenoid Valve

3-Way

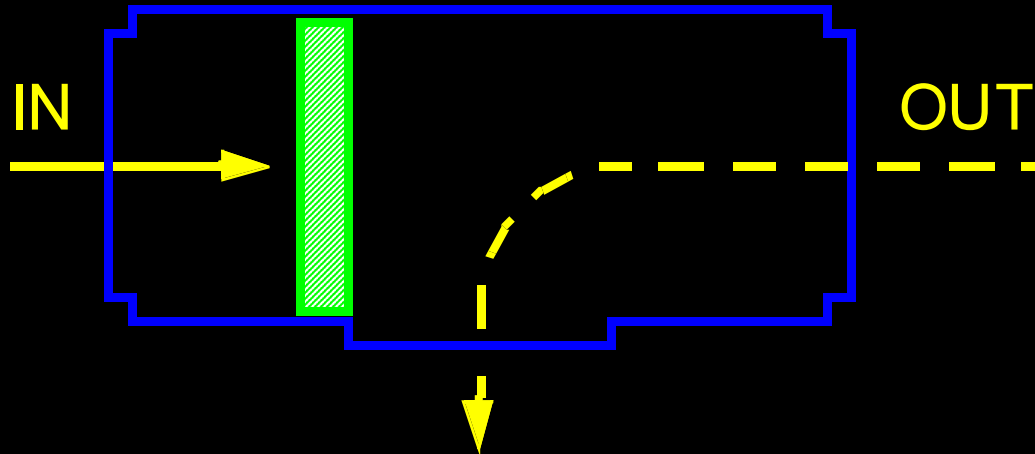

Air Cylinder

3-Way Solenoid Valve

Single Acting Air Cylinder

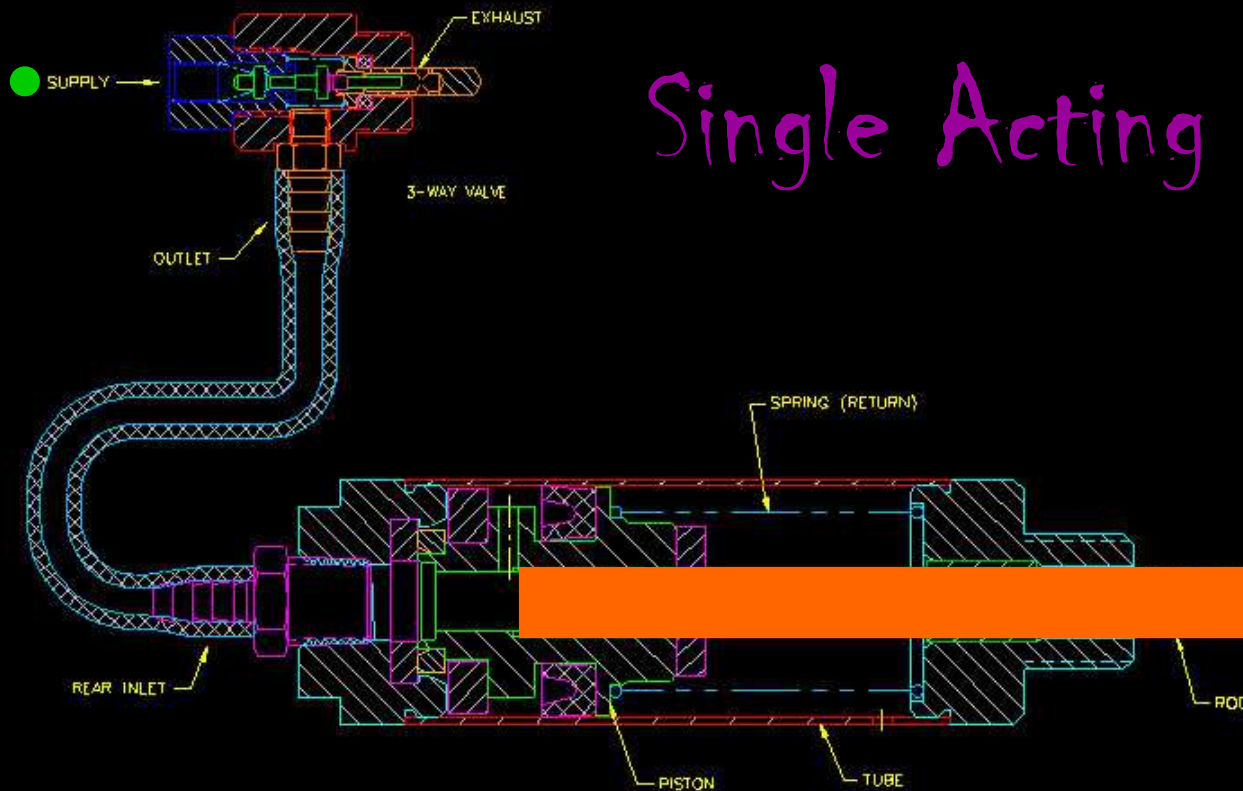

Air Cylinder

3-Way Solenoid Valve

Single Acting Air Cylinder

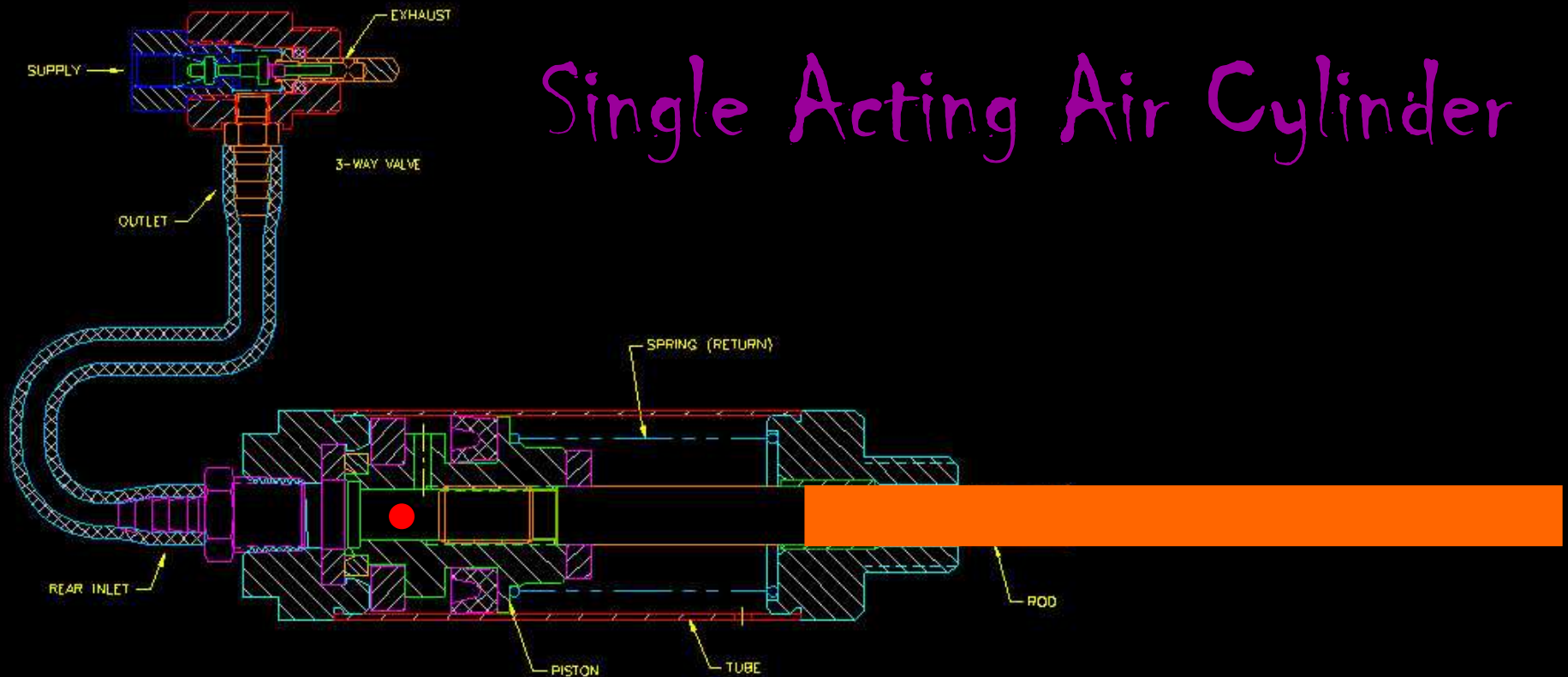

Solenoid Valve

4-Way



Solenoid Valve

4-Way

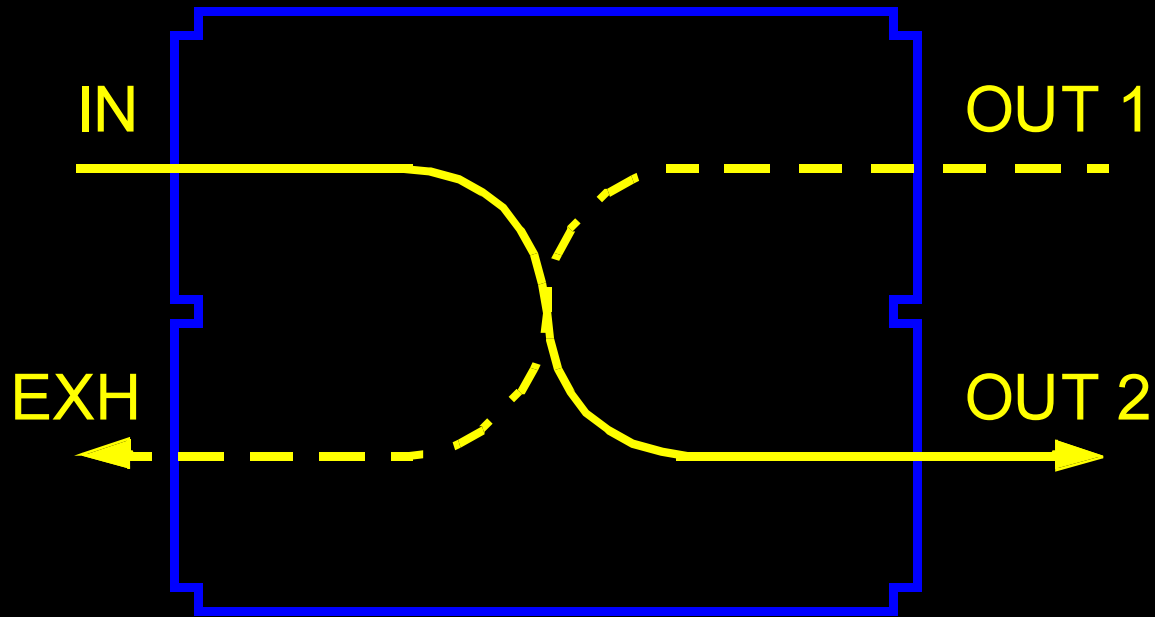

Solenoid Valve

4-Way, 5-Port

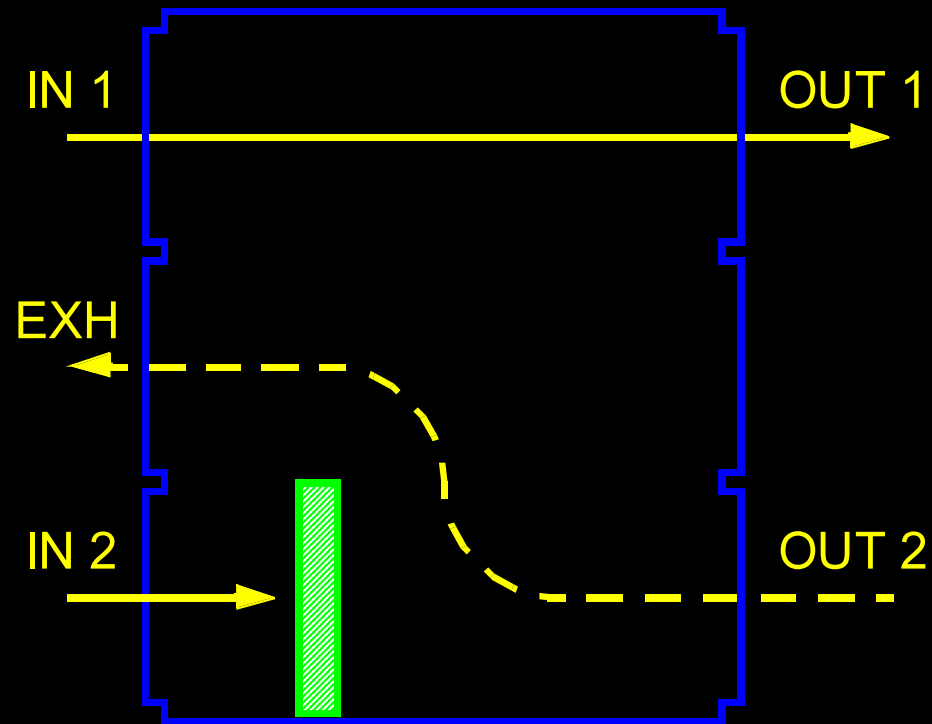

Solenoid Valve

4-Way, 5-Port

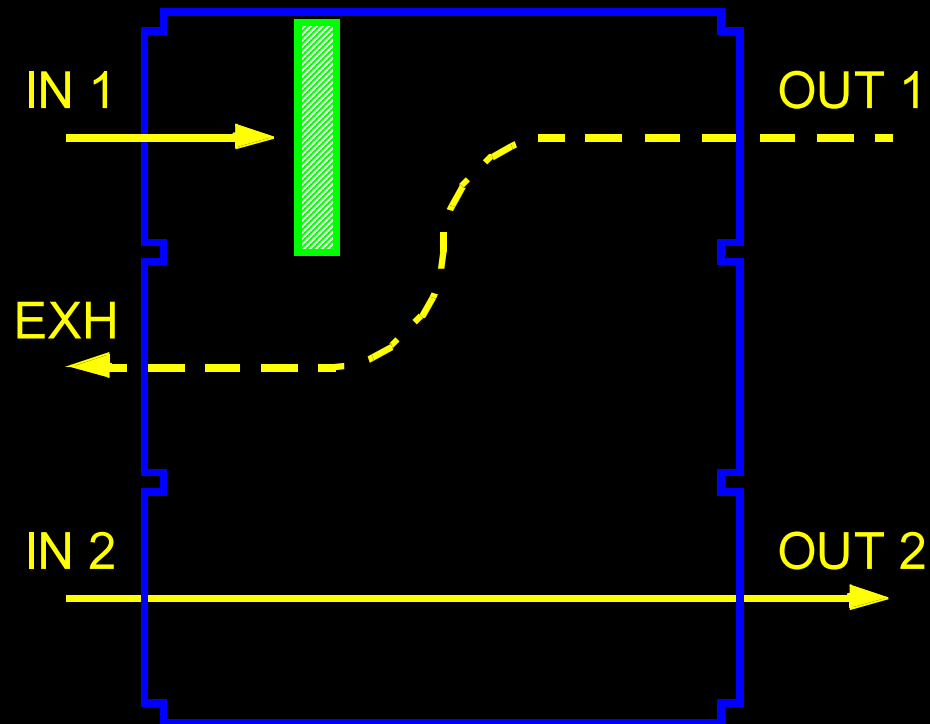

Solenoid Valve

4-Way, 5-Port

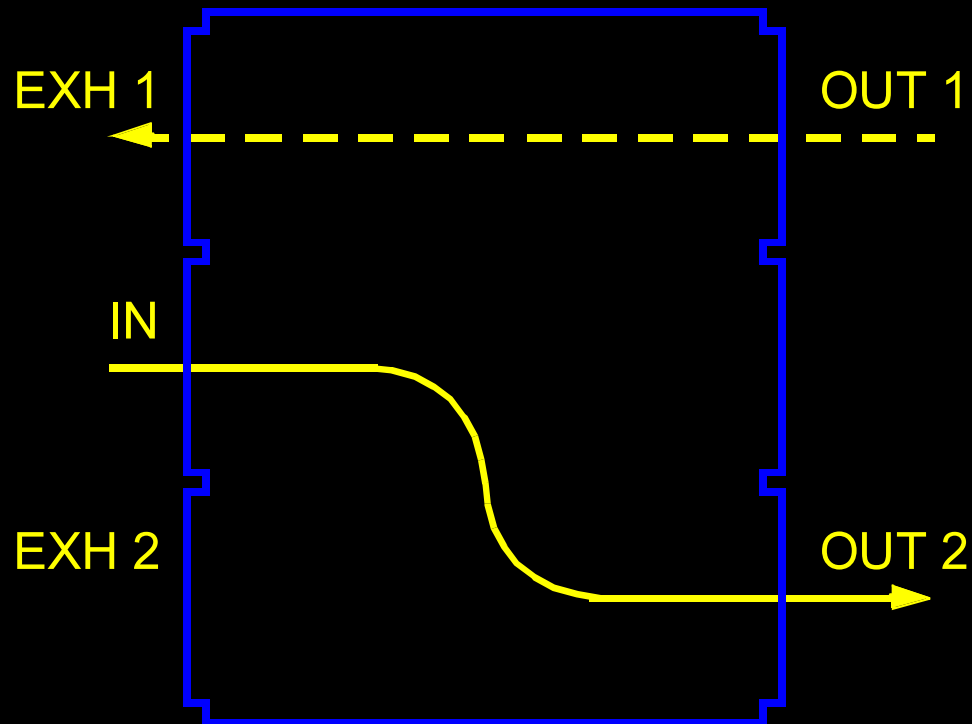

Solenoid Valve

4-Way, 5-Port

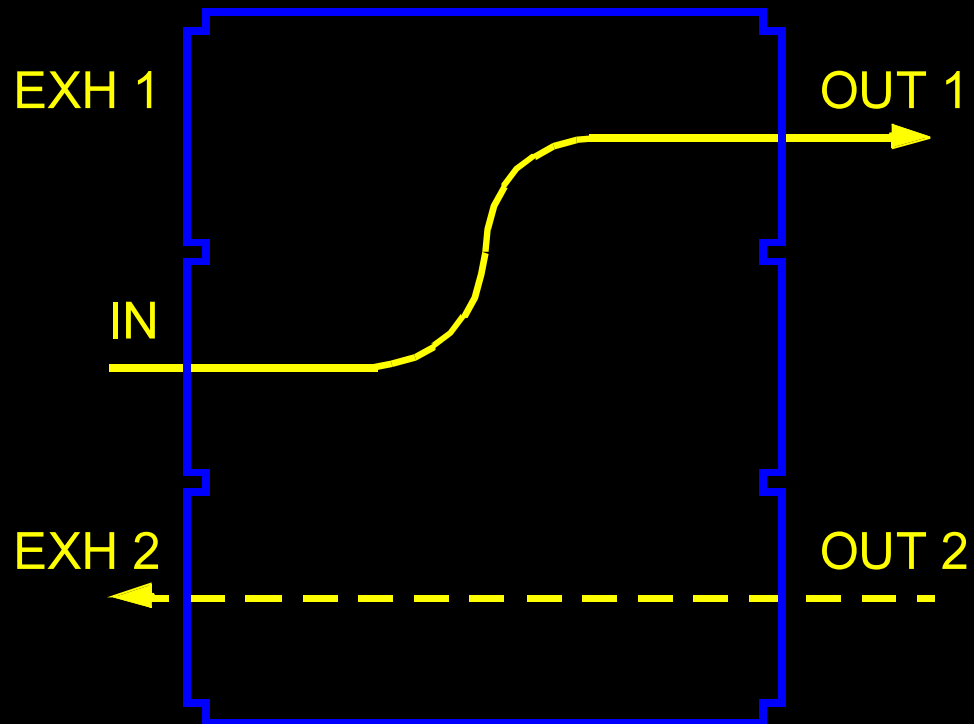

Air Cylinder

Double Acting, Stud Mount

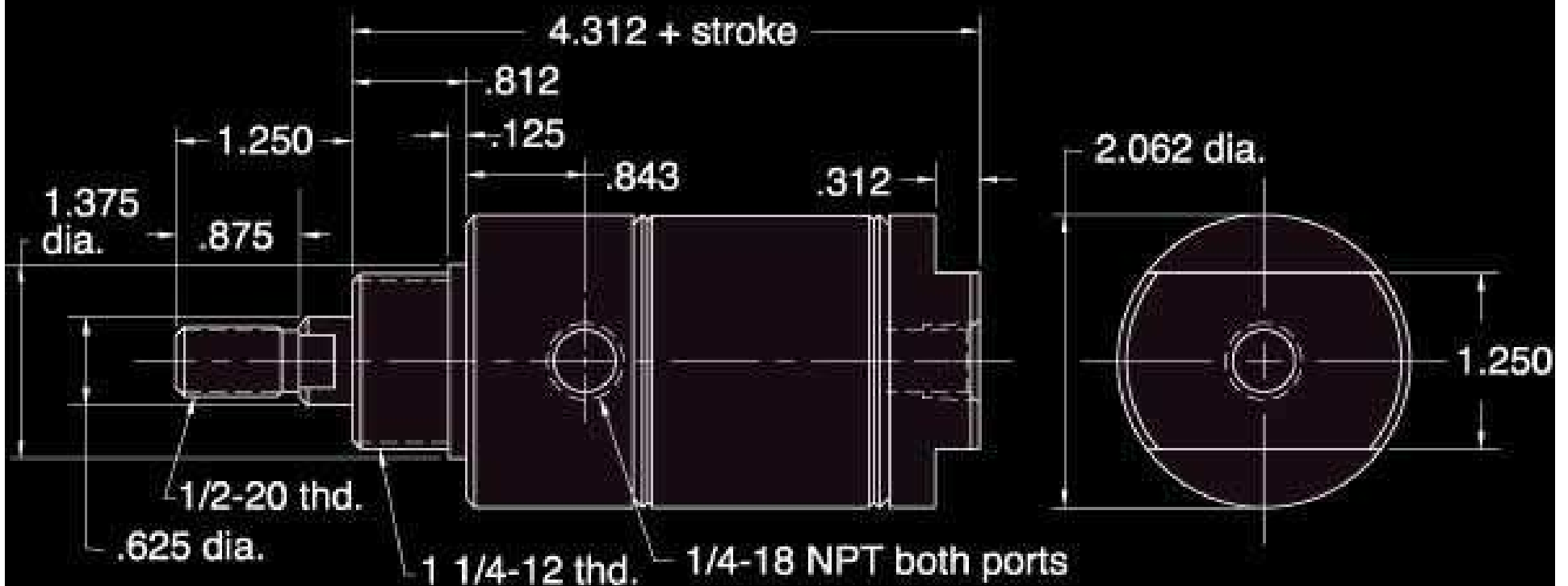

Air Cylinder (cont)

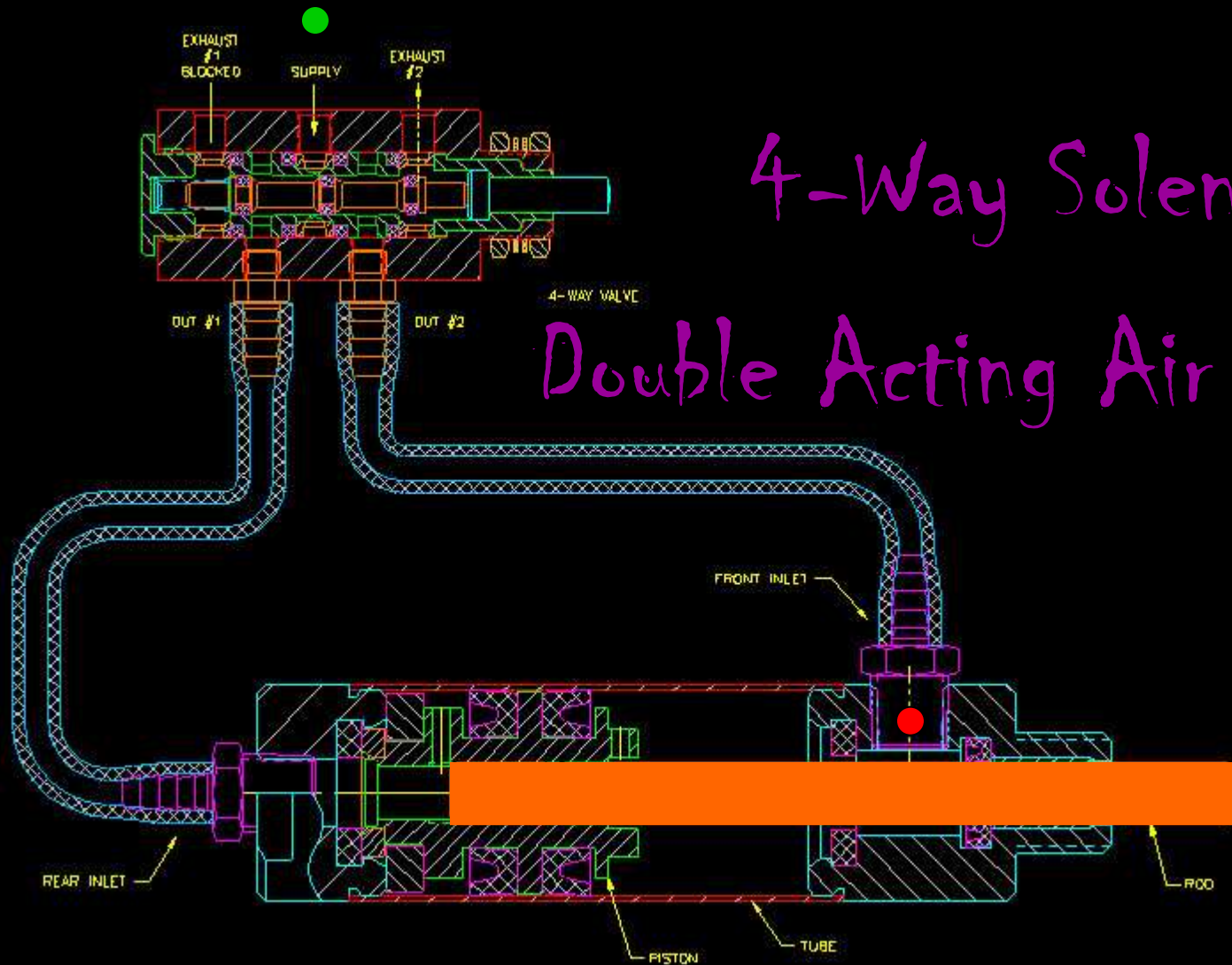

4-Way Solenoid Valve

Double Acting Air Cylinder

Air Cylinder (cont)

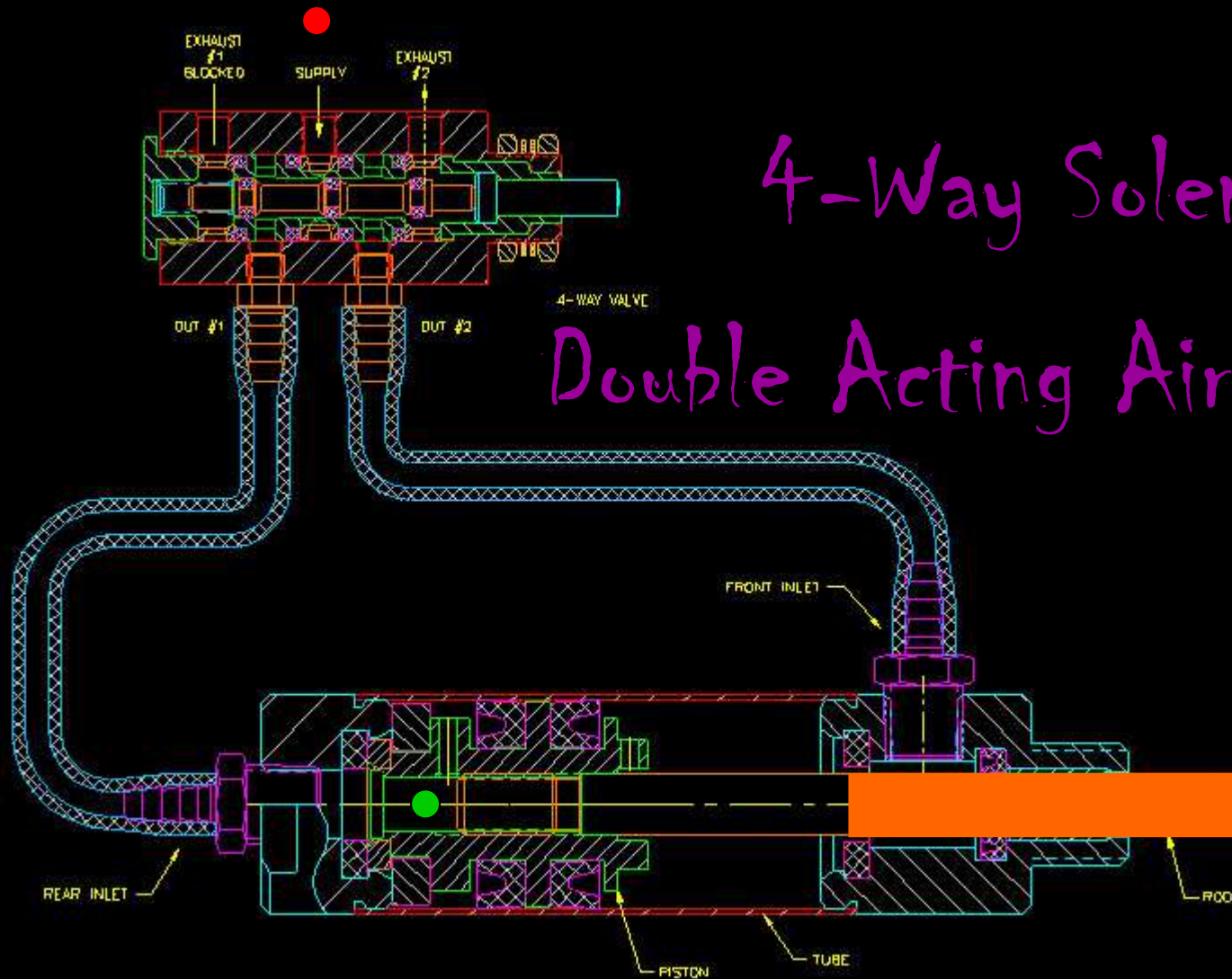

4-Way Solenoid Valve

Double Acting Air Cylinder

Air Cylinder (cont)

Double Acting, Universal Mount

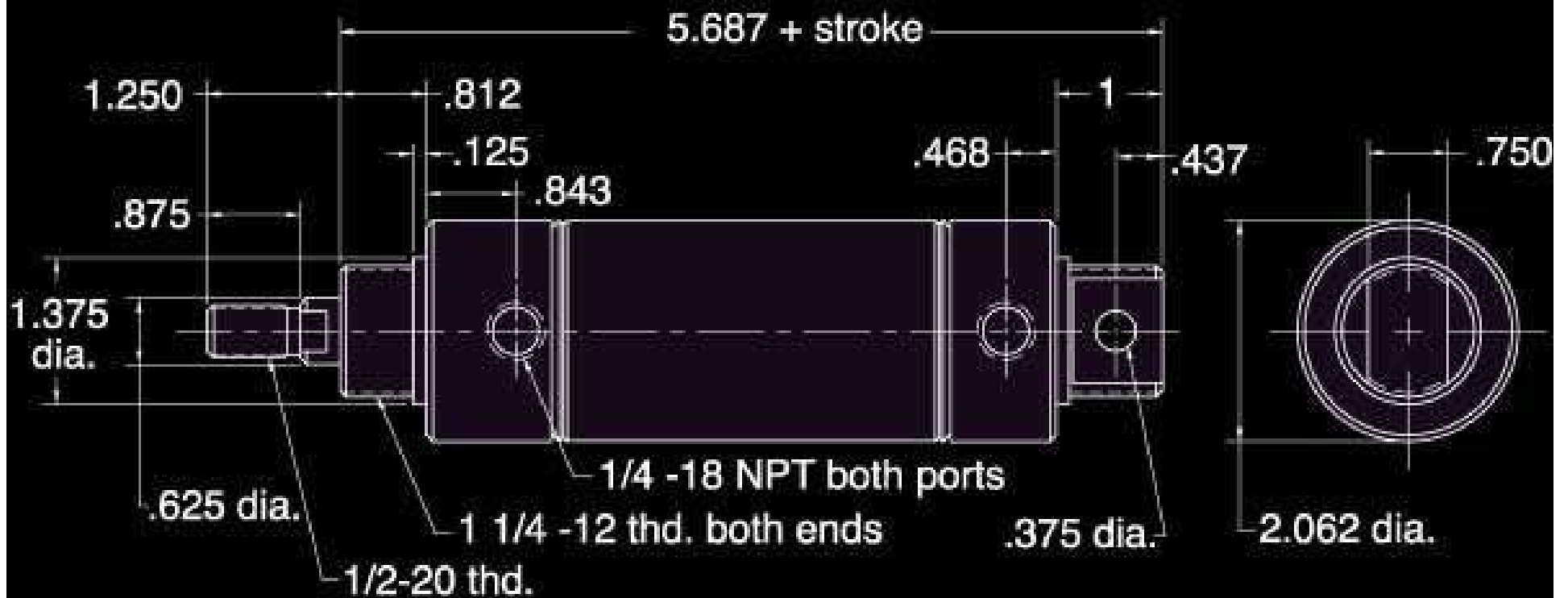

Force

Force = Airline Pressure x Power Factor

Power Factor = Piston Area

Piston Area = $\pi \times r^2 = 3.141 \times (\text{Bore} \div 2)^2$

Force (cont)



Force = Airline Pressure x Power Factor

Power Factor = Piston Area

Piston Area = $\pi \times r^2 = 3.141 \times (\text{Bore} \div 2)^2$

Force (cont)



Bore	Power Factor	Pressure			
		20 PSI	50 PSI	80 PSI	100 PSI
5/16"	0.07	1.4	3.5	5.6	7.3
7/16"	0.15	3	7.5	12	15
9/16"	0.25	5	12.5	20	25
3/4"	0.4	8	20	32	40
7/8"	0.6	12	30	48	60
1 1/16"	0.9	18	45	72	90
1 1/4"	1.2	24	60	96	120
1 1/2"	1.7	34	85	136	170
1 3/4"	2.4	48	120	192	240
2"	<u>3.1</u>	62	155	248	310
2 1/2"	5.0	100	250	400	500
3"	7.0	140	350	560	700

$$\text{Force} = \text{Airline Pressure} \times \text{Power Factor}$$

$$\text{Power Factor} = \text{Piston Area}$$

$$\text{Piston Area} = \pi \times r^2 = 3.1416 \times (\text{Bore} \div 2)^2$$

Pressure Regulator

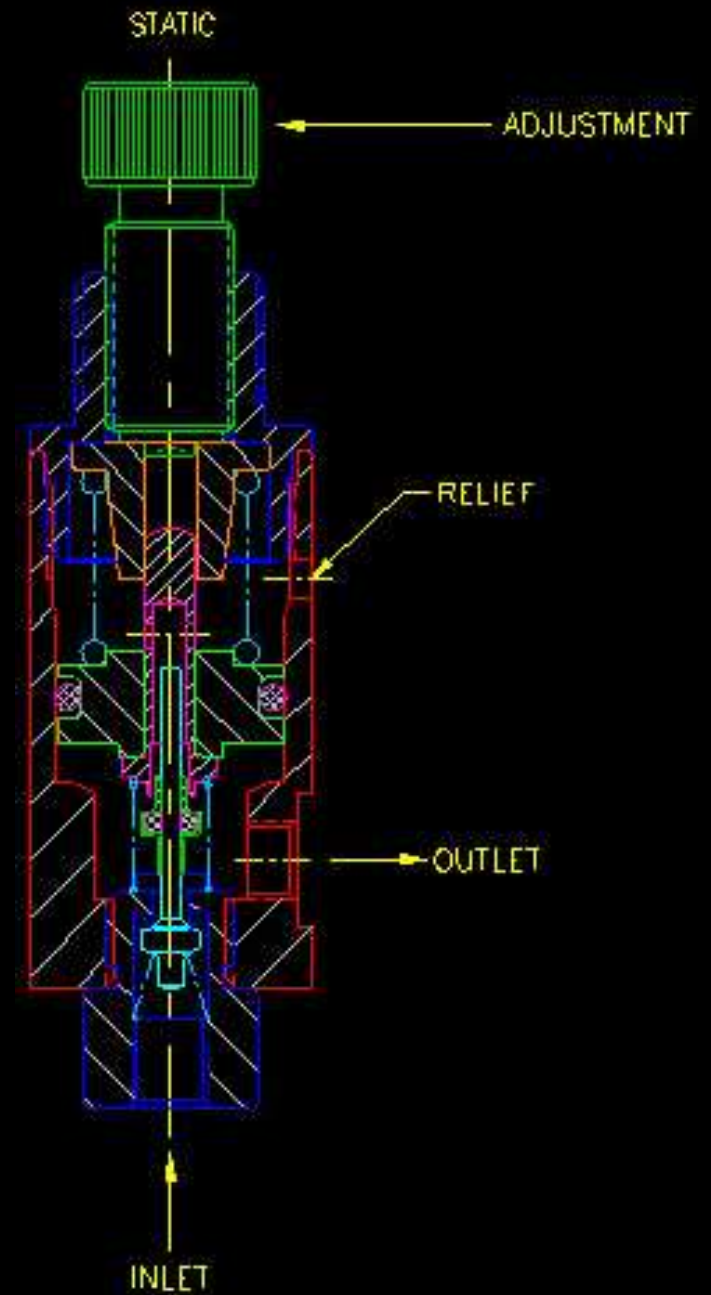

Valve Types

Elbow Flow Control Valve

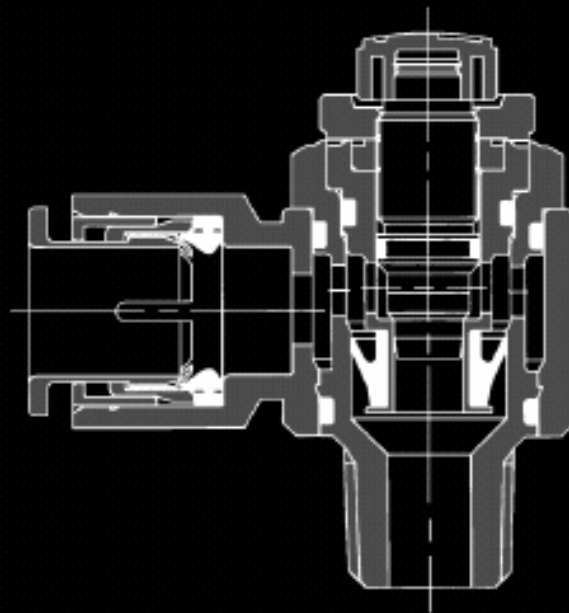

Valve Types (cont)

In-Line Flow Control Valve

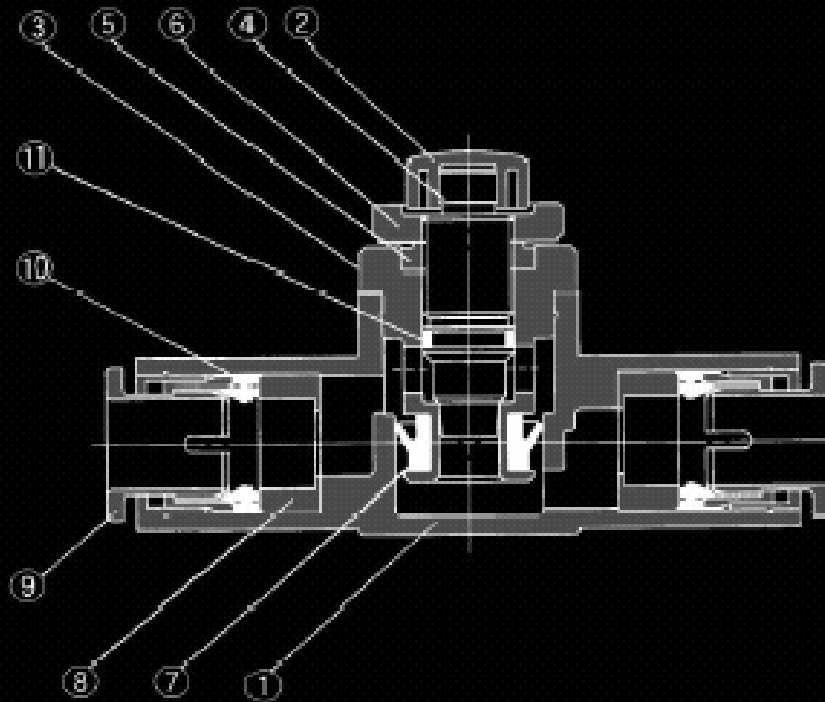

Valve Types (cont)

Safety Valve

Control Devices ST25-125 - \$6.57 *

- **Preset 125 PSI**
- **1/4" NPT**

* - **Grainger Item: 5A708**



Reservoir

Portable Air Tank

Campbell Hausfeld KT0700 - \$20

- 7 G
- Pressure Gauge
- **125 PSI Max ***

*** - Incorporate a safety valve!!!**



<http://www.walmart.com>

Reservoir (cont)

Portable Air Tank

Campbell Hausfeld KT0500

- 5 G
- Pressure Gauge
- **125 PSI Max ***

*** - Incorporate a safety valve!!!**



Quick Exhaust Valve

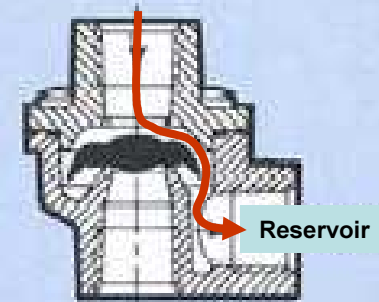
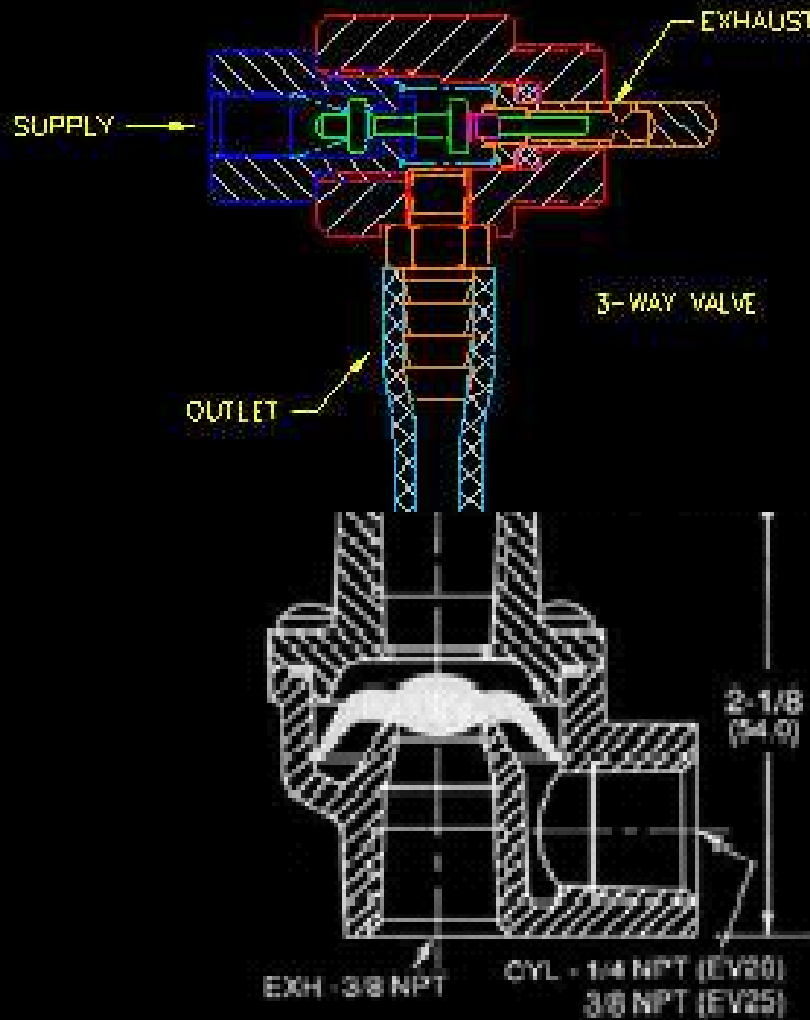

Figure A

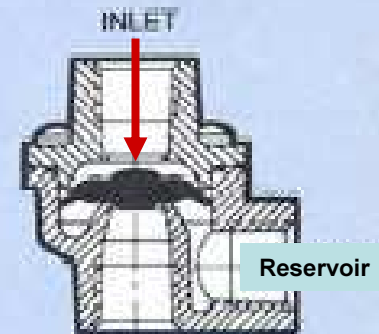

Figure B

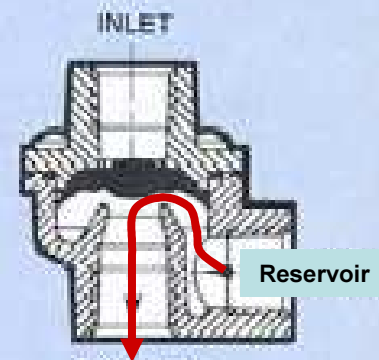
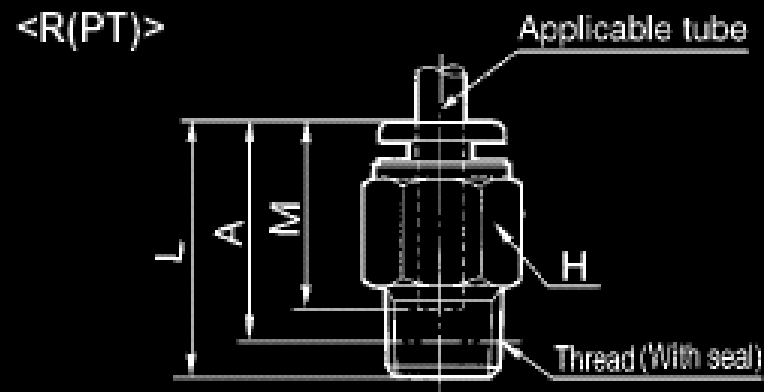

Figure C

Accessories

Male Connector One-Touch Fitting



Accessories (cont)

Male Elbow One-Touch Fitting

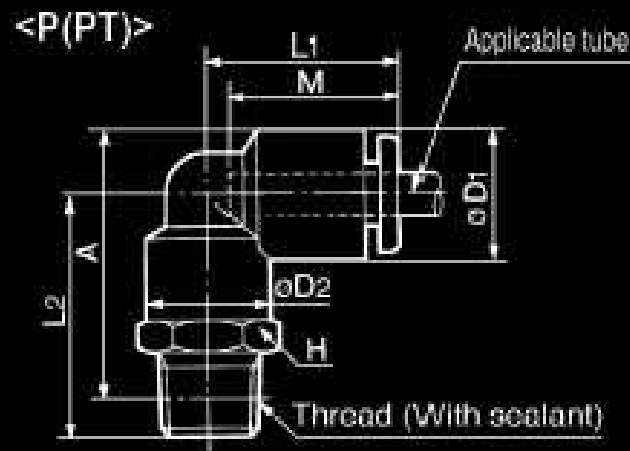

Accessories (cont)

Clevis Bracket

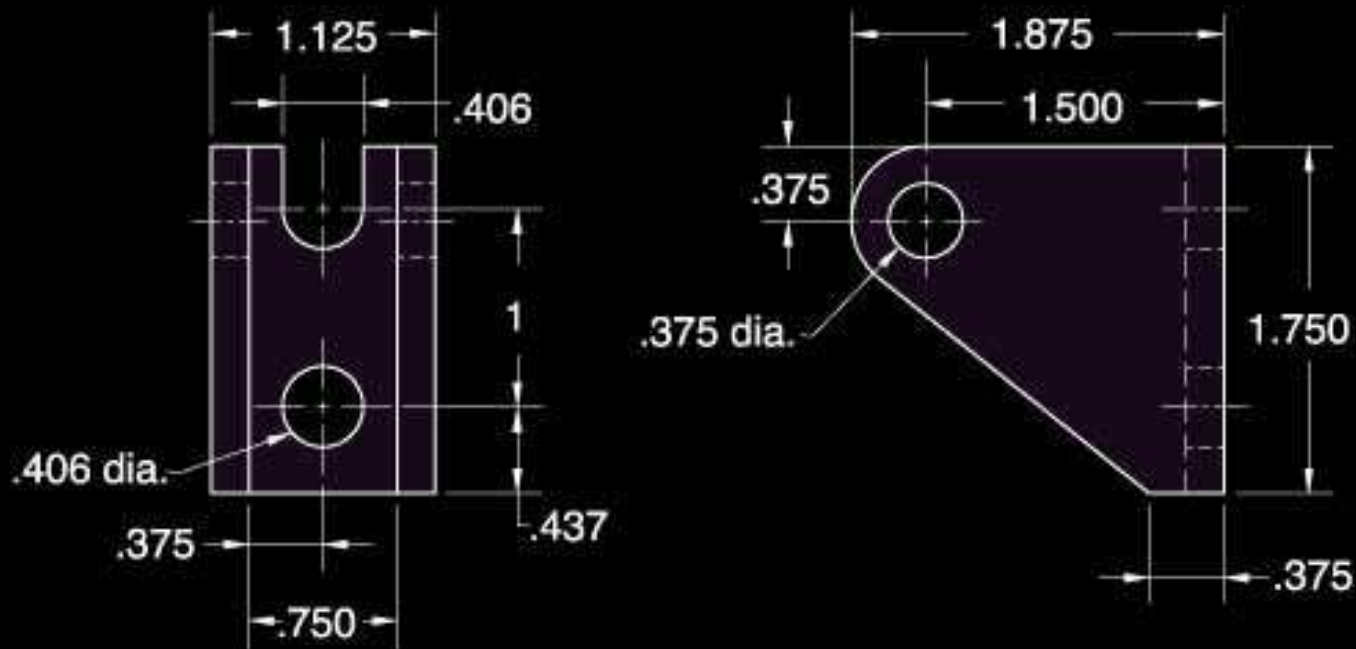

Accessories (cont)

Rod Clevis

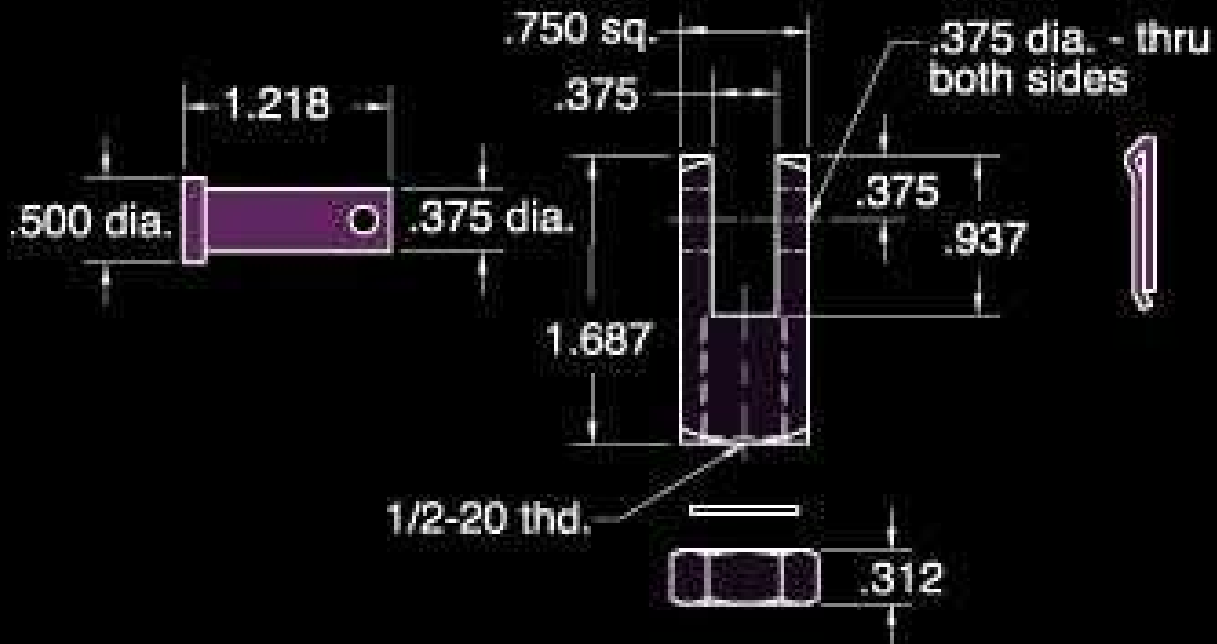

Accessories (cont)

Foot Bracket

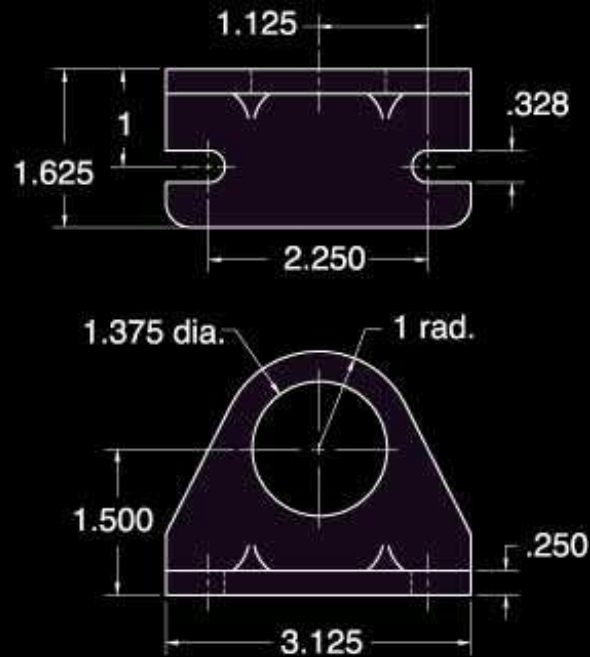

Haunt Mechanics



Haunt Mechanics (cont)

Accordion Linkage

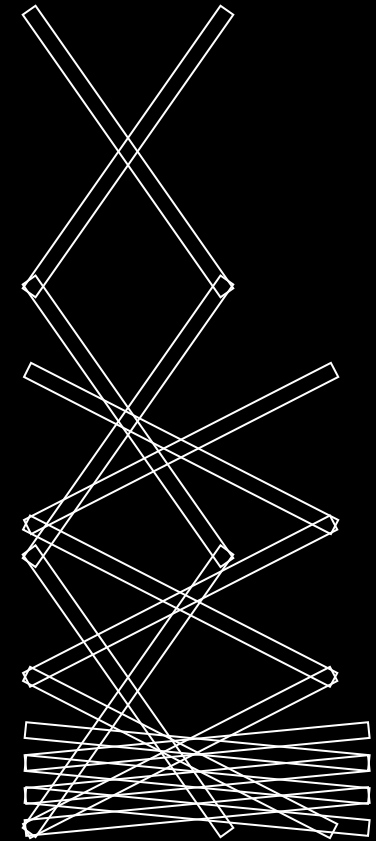

Haunt Mechanics (cont)



Haunt Mechanics (cont)

Four-Bar Linkage

A – Ground

B - Coupler (the bar whose motion we are trying to control)

C - Crank (the driven bar)

D - Follower

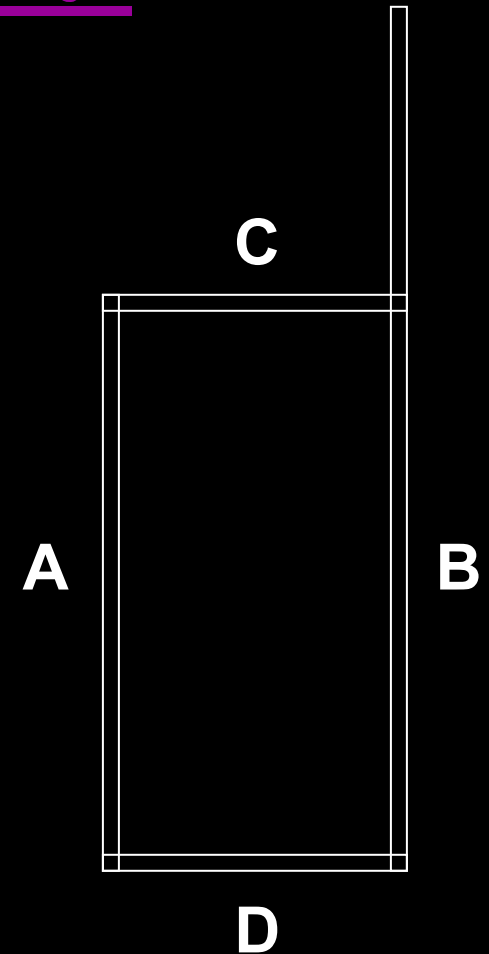

Haunt Mechanics (cont)

Four-Bar Linkage

A – Ground

B - Coupler (the bar whose motion we are trying to control)

C - Crank (the driven bar)

D - Follower

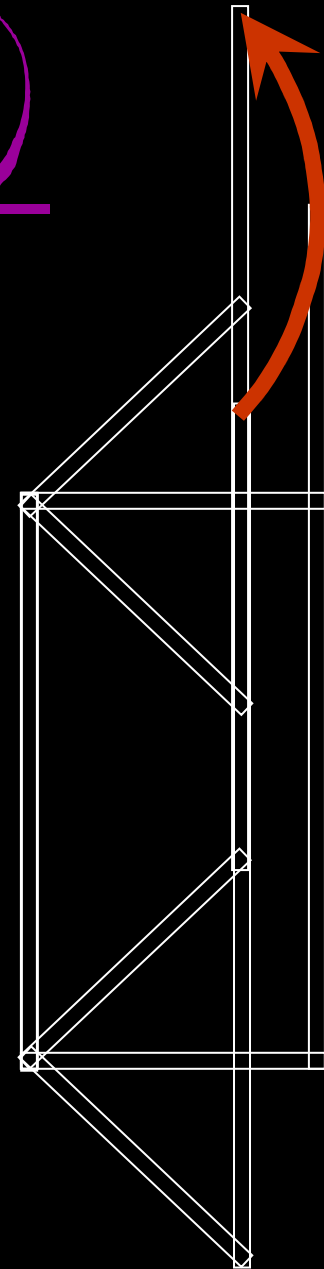

Haunt Mechanics (cont)

Four-Bar Linkage

A – Ground

B - Coupler (the bar whose motion we are trying to control)

C - Crank (the driven bar)

D - Follower

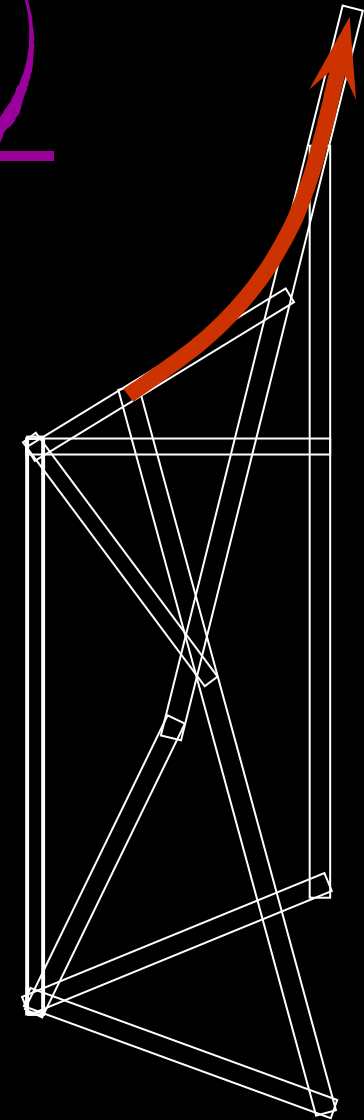

For More Information



<http://www.methodzofmadness.com>

For More Information (cont)



<http://www.wickedstone.com>

For More Information (cont)

SMC

<http://www.smcworld.com>

Bimba

<http://www.bimba.com>

Clippard

<http://www.clippard.com>

ASCO

<http://www.ascovalve.com>

For More Information (cont)

Grainger

<http://www.grainger.com>

Deltrol Fluid Products

<http://www.deltrolfluid.com>

Sears (Craftsman)

<http://www.sears.com>

Home Depot

<http://www.homedepot.com>

For More Information (cont)

Animatronics: A Guide to Animated Holiday Displays

Edwin Wise, Sams Technical Publishing

<http://www.simreal.com>